

# HYDRA-MATIC TRANSMISSION

## GENERAL DESCRIPTION

The 1955 Hydra-Matic transmission, available as standard equipment on all series Cadillac cars, is essentially the same as previous models. However, to compensate for an increase in engine horsepower, some changes have been incorporated to provide further improvements in performance. In addition, four Hydra-Matic transmissions, each one slightly different than the other, are used in 1955. Model application of these transmissions are as described below.

The design of the torus members on the model "CE" transmission used with the Eldorado engine, and the heavy loads imposed on the model "A" commercial chassis transmission, necessitate the use of an oil cooler on these assemblies to regulate the transmission oil temperature, thus assuring normal operation and life of the various units in the transmission.

The oil cooler assembly is mounted on the right side of the transmission, where coolant from the rear of the right hand engine block is employed to cool the oil. The heat laden coolant then returns to the cooling system at the heater hose fitting on the water pump, where it is directed to the radiator.

Oil from the rear pump is directed to the cooler assembly through a control valve which opens when rear pump pressure reaches 60 P.S.I. After the oil passes through the cooler, it returns directly to the transmission oil pan.

In addition to the specific changes noted above, other improvements have been incorporated in 1955, which apply to all four Hydra-Matic transmissions.

The front unit gear ratio has been increased from 1.45 to 1.55 to 1. This results in an increase in torque and overall performance in first, third and reverse. In DR-3 range, more positive engine braking is possible when descending steep grades, with increased torque when ascending.

To accomplish the gear ratio change, the front unit planet carrier has been redesigned providing smaller pinion gears. This also allows removal of the bronze thrust washer from the planet carrier. The steel backing washer in the carrier has been eliminated because of the larger thrust area on the front unit drive gear. Likewise, the internal teeth of the front unit drive gear have been changed to conform with the planet pinions. Accordingly, the front unit clutch cover and gear has been changed to accommodate changes to the planet carrier pinions.

The front and rear clutch piston outer oil seals for 1955 consist of cast iron seal rings in place of the expander and neoprene type seal. This requires new annular pistons in which oil seal grooves are machined. The cast iron seal ring gap allows some oil to pass through, which improves the cooling characteristics of clutch apply oil without sacrificing effective clutch pressure and also improves durability of the unit. The circulation of oil through the cast iron seal ring is exhausted through the 1-2 orifice which has been increased from .078" to .094" in diameter.

In 1955, the 4-3 hydraulic valve action in the front servo has been changed to provide a more positive apply on a 2-3 upshift to improve shifting.

## TRANSMISSION IDENTIFICATION

Serial No.	Series	Special Features
55-C-1001	60, 62 Except Eldorado	Groove at rear end of output shaft eliminated.
55-B-1001	75	Output shaft groove retained for yoke retention.
55-A-1001	86 (Commercial)	1. Output shaft groove retained for yoke retention. 2. Oil cooler attached to right side of transmission.
55-CE-1001	6267SX (Eldorado) and all dual carburetor engines.	1. Output shaft groove eliminated. 2. Oil cooler attached to right side of transmission. 3. Smaller torus members raise stall speed to correspond with peak engine torque RPM. 4. G-1 Governor weight reduced to permit higher shift points. 5. 2-3 Shift valve spring and overcontrol valve spring weaker to prevent shifting at high RPM due to G-1 weight change.

## HYDRA-MATIC TRANSMISSION

To make certain that the 4-3 valve is in the open (unrestricted) position on all 2-3 upshifts, Fig. 14-1, and in the closed (restricted) position, Fig. 14-2, for all 4-3 downshifts in 1955, rear band release oil is directed against the large end of the 4-3 valve to close the 4-3 valve, whereas in 1954, G-1 oil was used. The rear band release oil is taken from a point in the rear servo body so that it becomes available only in 3rd and 4th speeds after the rear servo has completed its release stroke

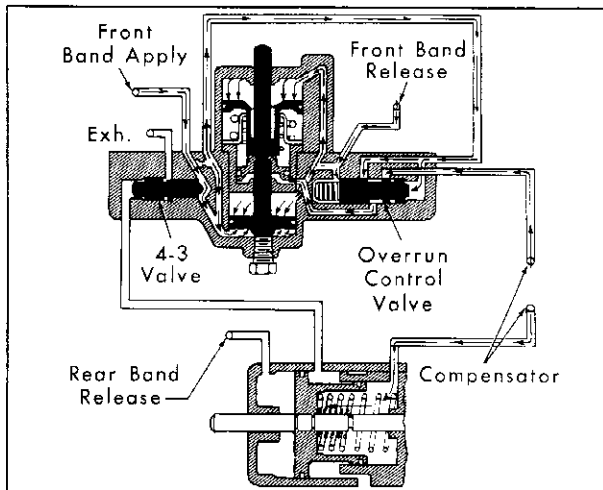

Fig. 14-1 Servo Action During 2-3 Upshift

(rear clutch applied - band released). This allows the front servo to complete its apply action on a 2-3 upshift before the apply passage is closed (restricted). On a 4-3 downshift, front band apply oil is metered, allowing the front clutch sufficient time to release before the band is applied.

Since G-1 oil is not directed to the front servo in 1955, restricted front band apply oil is used in place of G-1 oil in the overrun control valve. The overrun control valve directs the restricted front band apply oil in 3rd speed, and compensator oil for 2nd and 4th speeds, to the compensator piston. By use of a stronger overrun control valve spring and restricted front band apply oil, the apply action is smoother.

To incorporate the changes in the front servo action, the front servo body has been redesigned, eliminating the G-1 feed hole. The compensator feed hole is converted to an exhaust hole. A new feed hole in the front servo for the rear band release oil has been incorporated. The front servo valve body has been changed accordingly. In addition, the rear to front servo compensator pipe has been replaced with a new rear to front servo rear band release oil pipe.

The rear servo body has been changed to provide a greater holding force, accommodating the

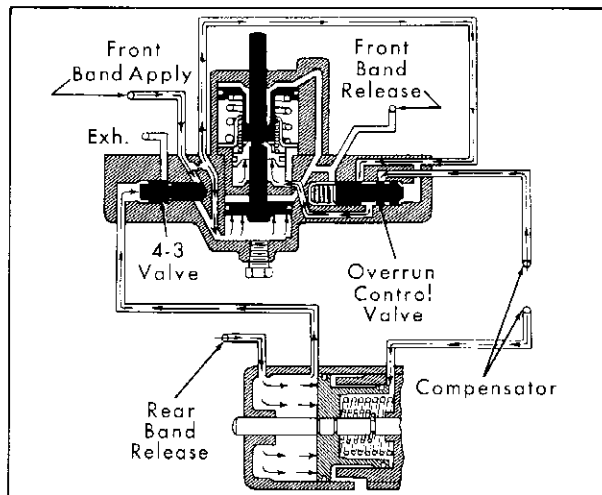

Fig. 14-2 Servo Action During 4-3 Downshift

new front unit gear ratio. To accomplish this, the effective length of the band actuating lever has been increased by relocating the clevis pin hole in the rear servo body. The rear band release oil feed hole in the rear servo is located just to the rear of the former (1954) compensator feed hole which has been eliminated in 1955. Fig. 14-3.

Two rear servo retainer to accumulator body lock washers have been eliminated in 1955. Sufficient locking action can be obtained by rear servo spring force against the retainer.

The flywheel housing consists of a one piece unit, whereas in 1954, the housing consisted of two separate pieces with a portion integral to the engine block. To accommodate this housing, the drain plug has been removed from the torus cover and installed at the outer edge of the front face of the flywheel. Flywheel to torus cover attaching screws are accessible from the front of the flywheel. Weld nuts have been installed on the back flange of the torus cover to engage flywheel bolts. A cover plate mounted at the lower, forward portion of the flywheel housing can be removed to permit access to the drain plug and attaching screws. This requires removal of the starter motor assembly.

A new 1-2 shift valve spring is used in 1955 to improve shift "feel" by raising the part throttle 1-2 shift point.

The 3-4 regulator plug diameter has been enlarged to provide a full throttle (not through detent) 4-3 downshift speed of approximately 34 M.P.H. as compared with approximately 27 M.P.H. in 1954.

The pressure regulator spring has been made stronger to provide an increase in line pressure. This necessitates a change in the regulator plug to accommodate the new spring.

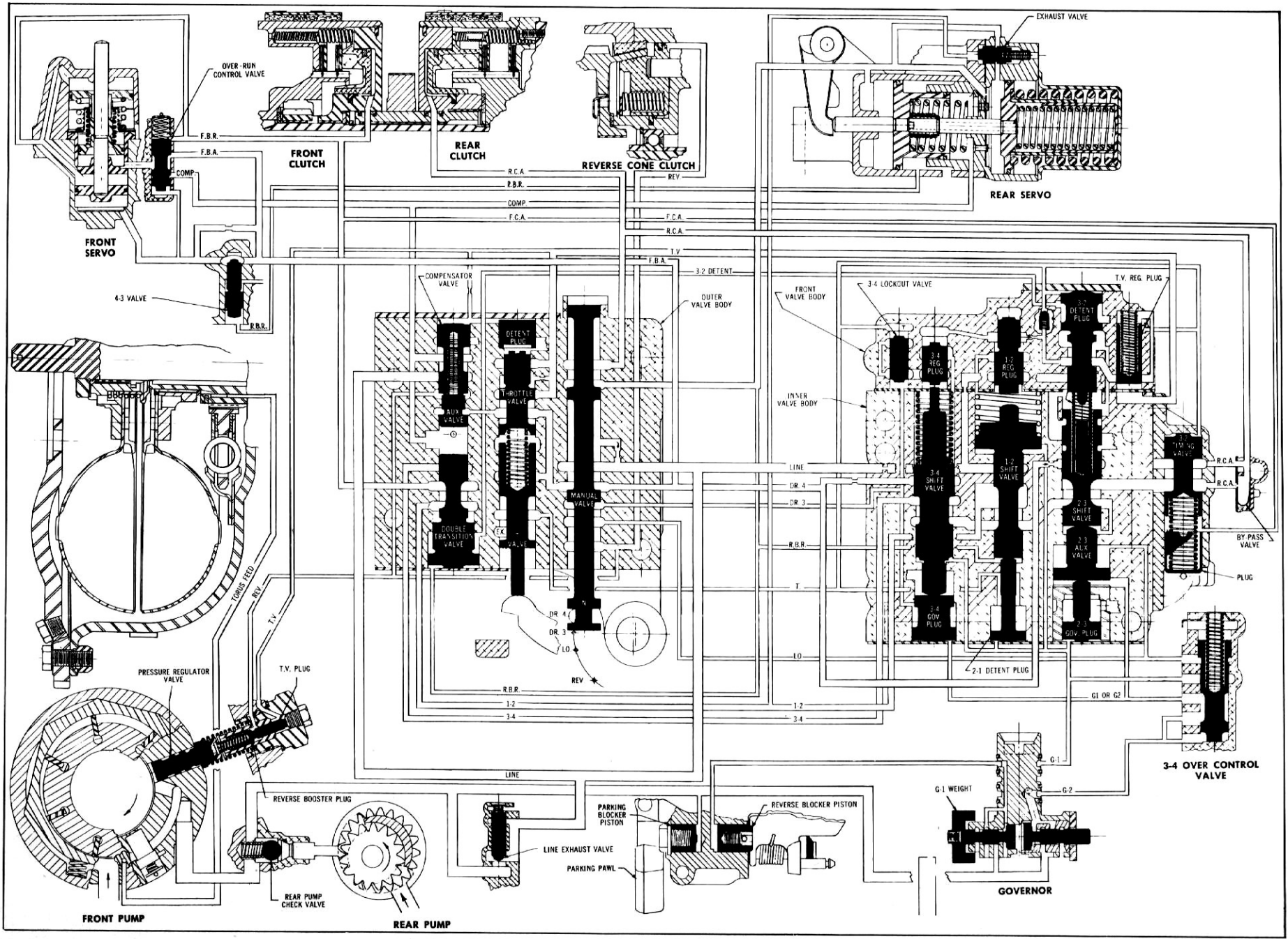

HYDRA-MATIC TRANSMISSION

Fig. 14-3 Hydra-Matic Transmission Oil Circuit

## HYDRA-MATIC TRANSMISSION

## SERVICE INFORMATION

With the exception of a few changes, the Service Information contained in the 1954 Shop Manual will be applicable to all 1955 Hydra-Matic Transmissions. Make certain the following information is thoroughly reviewed before proceeding with any service work.

**(1) Minor Changes****a. Correction of Leaks at Fluid Coupling**

Procedure for determining at which point leakage occurs will differ from 1954 because of the one piece flywheel housing used in 1955. Removal of the cover plate in front of the housing will permit checking for leaks at torus cover to flywheel bolts and at drain plug.

**b. Removal and Installation of Hydra-Matic Transmission**

The Hydra-Matic removal and installation procedure for 1955 is the same as in 1954 with the following exceptions:

1. With a one piece flywheel housing, there will be no lower cover to remove.

2. To reach the torus cover to flywheel mounting bolts, remove starter motor and flywheel housing front cover.

3. Drain the transmission, as described in Section 2, Note 10b.

4. On transmissions equipped with oil cooler, hoses at cooler must first be removed and hose ends plugged to prevent coolant leakage and entry of dirt or other foreign matter. When removing oil pan, exercise caution when disconnecting the pump feed line from the cooler valve body in the oil pan.

5. When installing transmission, observe changes noted above.

**c. Disassembly and Assembly of Transmission**

1. Planet Carrier - With smaller planet pinions, the bronze thrust washer inside the planet carrier can now be removed. Upon assembly, make certain washer is reinstalled.

2. Front and Rear Unit Outer Clutch Piston Seals - The outer clutch piston seals in the front and rear units for 1955 are cast iron ring seals, whereas in 1954 the seals consisted of an expander and rubber seal. Removal of the ring seal merely

requires expanding the ring until free of piston groove. When installing the piston and ring assembly, Tool No. J-5608 may be used to compress the seal ring until assembly is positioned in the clutch cover. Fig. 14-4.

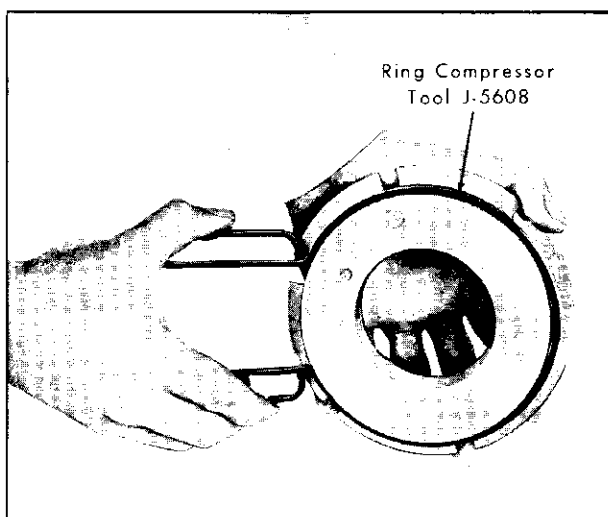

Fig. 14-4 Installing Clutch Piston Seal

The front unit oil seal ring gap must be held to specification. This is required to allow for more tolerance of the front clutch drum bore. All measurements must be taken with ring located squarely in clutch drum bore. To check ring gap, proceed as follows:

a. Insert oil seal ring squarely in clutch drum assembly.

b. Using a feeler gage, check the ring gap. The ring gap limits are .001"-.006" measured at the OD of the ring.

c. If gap is too tight, it may be filed to fall within limits.

NOTE: Care should be exercised not to file the ring gap so as to allow the OD to be longer than the ID. The maximum taper must be .007" gap at ID.

3. CONTROL VALVE ASSEMBLY - Service operations covering the control valve assembly remain the same as for 1954.

**(2) Throttle Control Linkage Adjustment**

1. Remove transmission throttle control clevis pin, and check lever position with Tool No.

## HYDRA-MATIC TRANSMISSION

J-3065-C by fitting tool to rear face of transmission case and inserting clevis pin through lever and 49 E 50 hole in tool while lever is in its rearward position. If throttle lever is misaligned, bring it into alignment by bending with Tool No. J-3310.

2. Assemble linkage to transmission throttle lever and install new cotter pin.

3. Remove spring clip from carburetor to dash relay rod trunnion and remove trunnion from relay lever.

4. Place 1/4 inch drill shank through gaging hole in dash relay lever and into dash relay bracket.

5. With engine running, set throttle lever in hot idle position. (Air Conditioner "off")

6. Adjust carburetor to dash relay rod trunnion to allow free entry into dash relay lever.

7. Install spring clip in trunnion.

8. On cars with single carburetor

(a) Back off both jam nuts on the T.V. rod at carburetor to allow free movement of rod in trunnion.

(b) Push end of T.V. rod to position transmission throttle valve against its stops.

(c) Bring rear jam nut up against trunnion and back off 8 flats (1-1/3 turn).

NOTE: This adjustment may be increased or decreased to improve shift characteristics after road test.

(d) Tighten front jam nut. Check to make certain linkage moves freely.

9. On cars with dual carburetors

(a) Remove lock nut, adjusting nut and spring from forward end of T.V. rod.

(b) Back off rear lock nut and adjusting nut on T.V. rod to permit free movement of rod in trunnion.

(c) Push on end of T.V. rod to position transmission throttle valve against its stop.

(d) Bring rear adjusting nut up against trunnion and back off 3 complete turns.

(e) Tighten rear lock nut.

(f) Install spring and adjusting nut on front end of T.V. rod.

(g) Adjust the nut until the distance between the front face of the trunnion and the rear face of the adjusting nut is 1-13/32". Fig. 14-5.

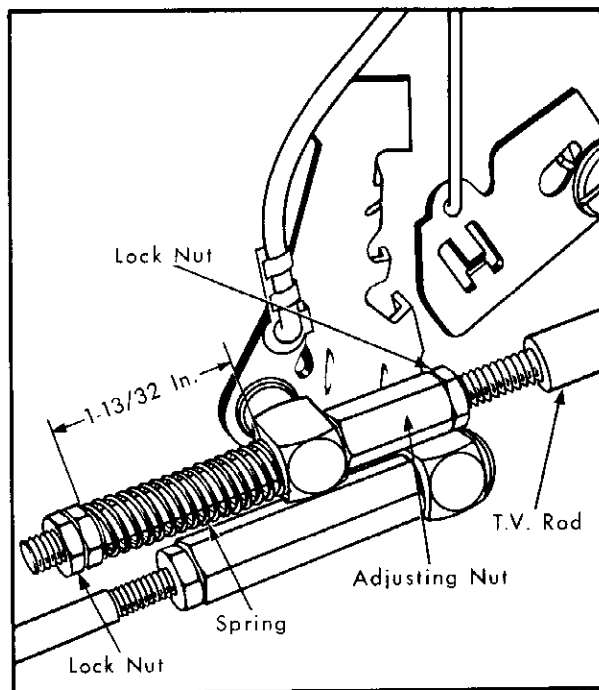

Fig. 14-5 T.V. Rod Adjustment - Eldorado Engine

(h) Install lock nut against front end T.V. adjusting nut.

10. Remove 1/4 inch drill shank from dash relay and check position of accelerator pedal with wide open throttle. Pedal should touch floor mat with slight pressure (allow 1/2" clearance if mat has been removed) when throttle is wide open.

11. Adjust accelerator pedal position at pedal end of dash relay to accelerator pedal rod.

12. Road test car to insure proper shifting characteristics.

### (3) Band Adjustments

To adjust bands on transmissions equipped with oil cooler will require draining of oil at the oil pan drain plug, disconnecting oil lines at pan, and removal of the oil pan.

NOTE: When removing oil pan, exercise caution when disconnecting the rear pump feed line from the cooler valve body in the oil pan. Make certain not to lose cooler valve and spring.

Upon installation of oil pan, be certain that the

## HYDRA-MATIC TRANSMISSION

rear pump feed line is properly installed into the oil pan cooler valve body.

### (4) Checking Pump Pressure

The pump pressure can be checked with the transmission in the car, using a gage calibrated to at least 250 P.S.I.

1. Remove band adjusting hole cover from floor pan, clean dirt from top of case and remove plug from top of transmission case (between band adjusting screws).

2. Screw pressure gage line fitting into hole in case, with gage placed so it can be read from the driver's seat.

3. Drive car until transmission oil has reached normal driving temperature (approximately 200°F).

#### a. Drive Range Check

The following tests may be made by road test or with car on jack stands.

1. At 400 RPM, the pressure should be 50 P.S.I. minimum in all ranges except reverse which could be higher.

2. Zero throttle pressure - At 30 MPH in fourth gear with zero throttle, line pressure should be 73 to 81 P.S.I.

3. Full throttle pressure (road test) - Full throttle pressure in fourth gear at 35 MPH (full throttle without going through detent) should be 114 - 122 P.S.I.

4. To check the operation of the rear pump alone, drive the car at 40 to 45 MPH in fourth speed. Then shift to neutral and turn off the ignition. Pressure should be at least 70 P.S.I.

Low rear pump oil pressure should be corrected by replacement of the pump gears or by checking for leakage in other units.

#### b. Reverse Pressure Check

1. Place the selector lever in reverse position and note pressure with engine running at 400 RPM. This reading should be as high or higher than the previous pressure checks in drive range.

2. With the selector lever in reverse, apply the foot brake and increase engine speed to half throttle. Pressure should increase to 176 P.S.I. minimum. The pressure range under the above conditions is 176 P.S.I. minimum.

If pressure readings are below the specified amount for any of the above tests, a malfunctioning pressure regulator or a leak in the system is indicated.

### (5) Removal and Installation of Oil Cooler Assembly

#### a. Removal and Installation of Cooler Assembly Only

1. Disconnect coolant hoses at cooler and plug open ends to prevent coolant leakage and entry of dirt or other foreign material.

2. Disconnect two oil lines at cooler.

3. Remove screws retaining cooler to oil pan and case and remove cooler.

4. To install, reverse procedure described above.

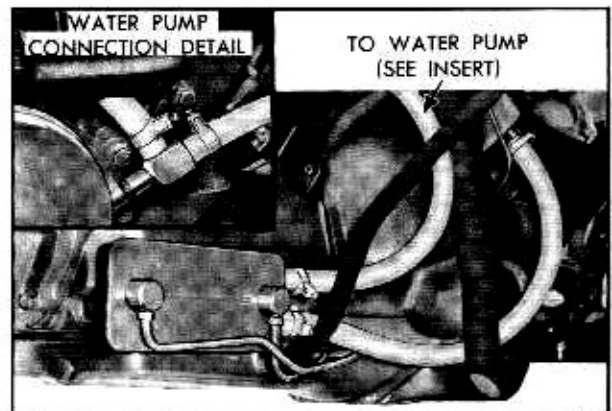

Fig. 14-6 Oil Cooler Hose and Pipe Connections

#### b. Removal and Installation of Oil Pan Equipped with Cooler Assembly

NOTE: This operation is required when adjusting bands or disassembling transmission.

1. Drain oil from transmission at oil pan drain plug.

NOTE: Fluid coupling need not be drained for this operation.

2. Disconnect oil lines at oil pan.

3. Remove oil pan making certain not to bend or distort the rear pump to cooler valve body feed line.

NOTE: When oil pan has been removed, locate valve and spring in cooler valve body to make certain parts are not lost in removal.

## HYDRA-MATIC TRANSMISSION

4. If it is necessary to replace cooler, disconnect hoses and remove cooler. Make certain hoses are plugged to prevent leakage of coolant.

5. Inspect all parts for evidence of wear, damage and foreign material. Clean and replace parts if necessary.

6. To install oil pan, reverse procedure described above, making certain rear pump feed line is positioned properly in the cooler valve body.

8. Remove steering column lower cover.

9. Remove Hydra-Matic dial pointer.

10. Remove directional signal switch.

11. Remove screws holding upper bearing retainer to steering jacket.

12. Remove cotter key, dust shield and horse-shoe retainer at lower shift lever on steering tube and then disengage shift lever from shifter tube.

13. Pull shifter tube up out of the steering jacket and then unscrew bearing retainer from shifter tube.

14. To install, reverse above procedure.

### (6) Towing Instructions

Cadillac cars equipped with Hydra-Matic transmission should NEVER be towed unless the propeller shaft is disconnected, or the rear wheels are raised off the ground. This is necessary because of possible close production limits which might cause the front clutch to drag and possibly burn up.

The only exception to this rule would be in a situation where pushing would be for only one or two blocks maximum, transmission oil cold, for purposes of getting the car started. Speeds of 20-25 MPH must be maintained to insure proper lubrication.

#### b. Removal and Installation of Lower Shifter Lever

1. Remove steering column assembly from car as described in Section 7, Note 11.

2. Remove horn button and spring.

3. Remove steering wheel hub nut.

4. Remove steering wheel and spring.

5. Loosen lower steering column clamp and remove steering clamp and remove steering shaft and lower bearing.

6. Remove directional signal switch.

7. Remove selector lever and anti-rattle spring.

8. Remove screws holding upper bearing retainer to steering jacket.

9. Remove cotter key, dust shield and horse-shoe retainer at lower shift lever on steering tube.

10. Disengage shift lever from shifter tube and remove tube.

11. Remove lower shift lever.

12. Remove upper bearing retainer.

13. Press upper bearing from retainer.

14. To install, reverse above procedure.

### (7) Removal and Installation of Shifter Tube and Lower Shift Lever

#### a. Removal and Installation of Shifter Tube

The following procedure relates specifically to removal of shifter tube from car without removal of steering column assembly.

1. Disconnect battery.

2. Remove neutral safety switch and horn contact from lower steering column.

3. Remove horn button and spring.

4. Remove steering wheel hub nut.

5. Remove horn ring retainer and horn ring.

6. Remove steering wheel using special puller, Tool No. J-1859.

7. Remove steering shaft tensioner spring and split ring.

## HYDRA-MATIC TRANSMISSION

## SPECIFICATIONS

Subject and Remarks	All Series
<b>FLYWHEEL COVER AND TORUS ASSEMBLIES</b>	
Flywheel Cover, maximum runout of hub . . . . .	0.005"
Backlash between splines of cover and front unit drive gear . . . . .	0.001" to 0.004"
Torus members, maximum runout of face . . . . .	0.015"
Drive Gear backlash between gear and planetary pinions . . . . .	0.005" to 0.008"
Planet Carrier Pinions, end play . . . . .	0.005" to 0.026"
<b>GOVERNOR ASSEMBLY</b>	
Maximum runout of governor sleeve . . . . .	0.005"
Maximum runout of governor drive flange face . . . . .	0.002"
<b>REAR OIL PUMP</b>	
End play of gears . . . . .	0.001" to 0.004"
Backlash of gears . . . . .	0.006" to 0.010"
Mainshaft, end play . . . . .	0.004" to 0.018"
<b>REVERSE ASSEMBLY</b>	
End play of planet carrier pinions . . . . .	0.005" to 0.026"
Backlash of internal gear pinions . . . . .	0.008" to 0.012"
<b>OUTPUT SHAFT ASSEMBLY</b>	
Backlash of pinions - Internal Gear . . . . .	0.0006" to 0.0008"
Sun Gear . . . . .	0.0003" to 0.0005"
End Play of Pinions . . . . .	0.005" to 0.026"

## TORQUE TIGHTNESS

Application	Size	Ft. Lbs. Min.	Ft. Lbs. Max.
Band adjusting screw lock nut . . . . .	1/2-20	40	50
Extension housing to case . . . . .	3/8-16	28	33
Extension housing to reverse unit support . . . . .	3/8-16	28	33
Flywheel to crankshaft . . . . .	7/16-20	80	85
Front cover retaining screws . . . . .	5/16-18	10	13
Front oil pump cover to body . . . . .	1/4-20	12	15
Front servo assembly . . . . .	1/4 pipe	6	7
Front servo body to cylinder . . . . .	1/4-20	6	8
Front servo to case . . . . .	3/8-16	23	28
Governor body to drive flange . . . . .	1/4-20	6	8
Governor bushing retainer to governor body . . . . .	10-24	3	4
Internal gear to rear drum . . . . .	10-24	3	4
Lever, shift on transmission . . . . .	5/16-24	18	22
Mainshaft, retaining nut . . . . .	7/8-16	30	35
Manual lever clamp screw . . . . .	5/16-24	10	13
Oil pan to case . . . . .	5/16-18	10	13
Oil pan drain plug . . . . .	5/8-18	35	45
Oil pressure take-off at case . . . . .	1/8 pipe	15	18
Outer valve body to inner body . . . . .	10-24	3	4
Pressure regulator valve plug . . . . .	1-1/16-16	40	50
Rear oil pump to case . . . . .	5/16-18	15	18
Rear pump cover to body . . . . .	1/4-20	6	8
Rear servo to case . . . . .	3/8-16	23	28
Reverse unit drive flange to rear unit drum . . . . .	5/16-18	10	13
Shifter bracket to case . . . . .	5/16-18	15	18
Side cover to case . . . . .	1/4-20	10	12
Throttle lever clamp screw . . . . .	1/4-28	10	12
Flywheel to Torus cover . . . . .	3/8-24	40	45
Torus cover drain plug . . . . .	1/8 pipe	6	7
Valve body to case . . . . .	1/4-20	6	8



## HYDRA-MATIC TRANSMISSION

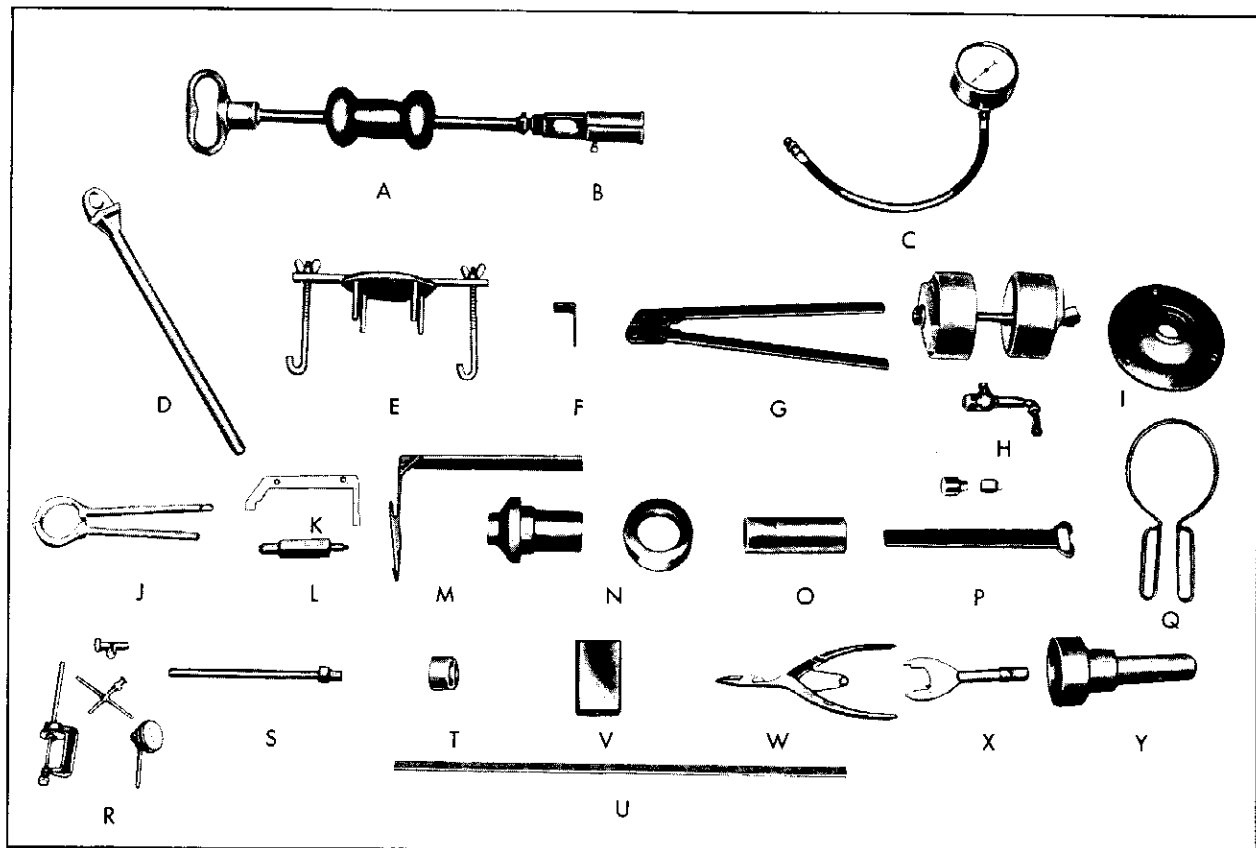

Fig. 14-7 Special Tools

KEY	TOOL NO.	NAME	KEY	TOOL NO.	NAME
A	J-2619-A	Slide Hammer	N	J-2170	Front Pump Cover Oil Seal Installer
B	J-2623	Ext. Housing Oil Seal Remover Collet	O	J-2587-B	Transmission Mainshaft End Play Gauge
C	J-2540-A	Pressure Checking Gauge	P	J-2184-A	Front Pump Holder and Socket Set
D	J-1459-A	Drum Holder	Q	J-1537	Oil Delivery Sleeve Ring Compressor
E	J-4670-B	Clutch Spring Compressor	R	KMO-30	Dial Indicator Set
F	J-2174	Rear Clutch Hub Retainer Bracket	S	J-1465-A	Mainshaft End Play Dial Indicator Extension Rod
G	J-3310	Throttle Lever Bending Tool	T	J-4731	Governor to Sleeve Aligning Tool
H	J-4353	Clutch Piston Actuator and Blow Gun	U	J-4752	Piston to Drum Installing Tool
I	J-2187	Front Planet Carrier Assembly Holder	V	J-5157	Regulator End Casting Assembly Clamp
J	J-1537	Oil Delivery Sleeve Ring Compressor	W	J-5586	Snap Ring Pliers
K	J-5071	Rear Servo Gauge	X	J-2182	Transmission Bearing Retainer Remover
L	J-1693-A	Front Servo Gauge	Y	J-1942-A	Extension Rear Oil Seal Installer
M	J-3065-C	Throttle Lever Checking Gauge			



## Band Adjustment — External Method

Before adjusting either front or rear band, set car hand brake, then chock wheels, making certain car does not move during adjustment.

To expose floorboard access cover over band-adjusting screws, remove accelerator pedal and lift floor mat on left (driver's) side. Remove access cover. Start engine. Run until normal operating temperature is reached.

Connect electrical tachometer.

For car models up to and including 1951, place Shift Lever in Low Range. For 1952 and later models, place Shift Lever in Drive Range.

Adjust carburetor idle screw until tachometer reads 700 RPM.

### Adjustment of Front Band

1. Insert Wrench End of Band Adjusting Tool in floorboard access hole (Fig. 4). Place Outer Socket over adjusting-screw lock nut. Engage adjusting screw by slowly rotating finger-grip Adjustment Knob until Inner Socket is seated.

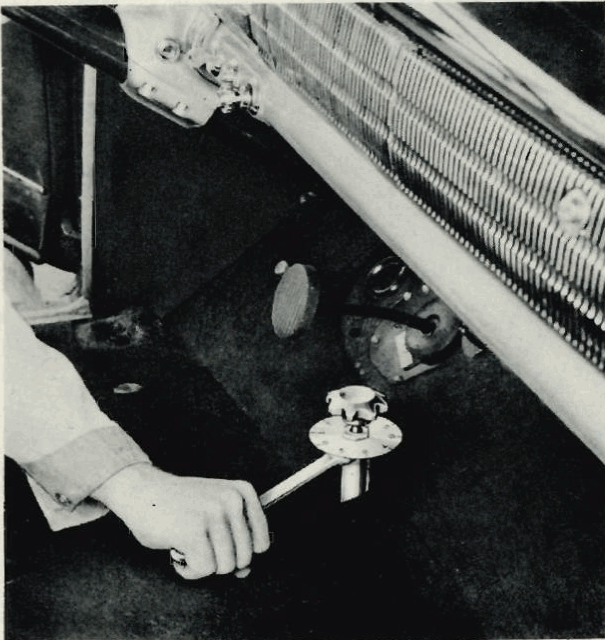

**Fig. 4. Adjusting bands external method**

2. Holding Adjustment Knob stationary, loosen lock nut by turning Wrench Handle in counter-clockwise direction.

3. Turn Adjustment Knob slowly in counter-clockwise direction, loosening adjusting screw, until engine speed reaches 900-1000 RPM.

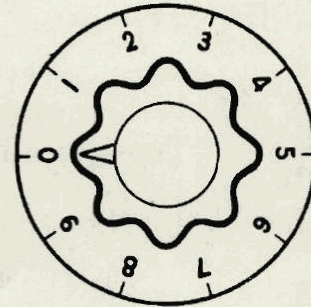

**Fig. 5. Indicator dial**

4. Reduce engine speed to exactly 700 RPM by slowly retightening adjusting screw. Observe tachometer for 30 seconds. If tachometer reading creeps up beyond 700 RPM, tighten adjusting screw 1/10th of a turn (one marking on Indicator Dial) and again observe tachometer. Continue this process until tachometer reading remains at 700 RPM for 30 seconds.
5. Without turning Wrench Handle or Adjustment Knob, rotate Indicator Dial until Zero mark is directly under arrow pointer (Fig. 5).

6. For car models up to and including 1951, hold Wrench Handle stationary and tighten adjusting screw  $6\frac{1}{2}$  turns by rotating adjustment knob in a clockwise direction. For

1952 and later models, tighten adjusting screw 7-7/10th turns.

7. Holding adjustment Knob stationary, tighten lock nut.

### Adjustment of Rear Band

1. Repeat operations 1 through 5, as in front-band adjustment procedure.

2. Place Shift Lever in Neutral position.

3. Hold Wrench Handle stationary and tighten adjusting screw 2 turns by

rotating Adjustment Knob in a clockwise direction.

4. Holding Adjustment Knob stationary, tighten lock nut.

5. Re-adjust carburetor for proper engine-idling speed.

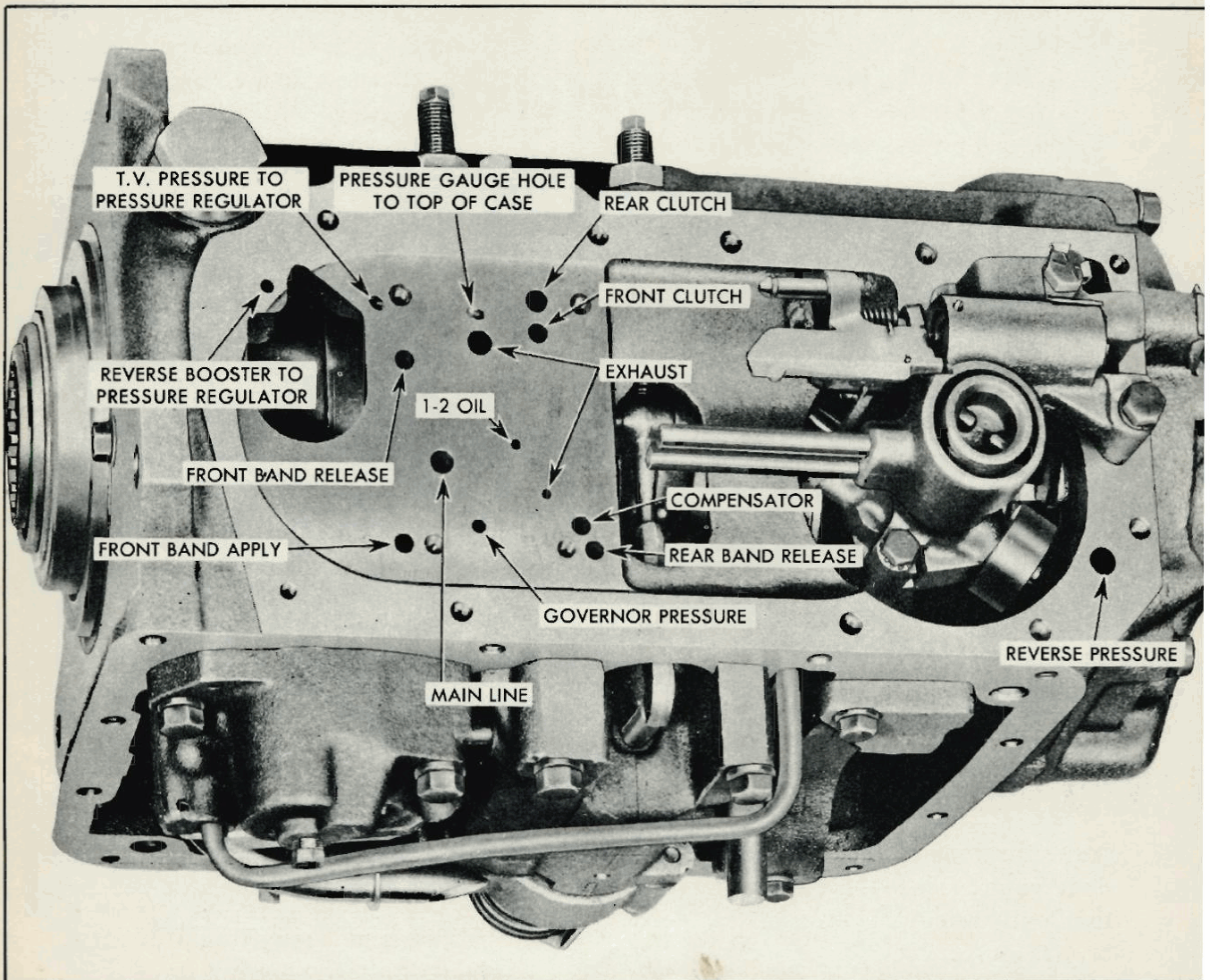

Passage identification — Hydra-Matic transmission